



3-Axis Indoor IR Dome
(with DC 12V / PoE)

ACM-3210 series

Ver. 081016

Hardware User's Manual



www.acti.com

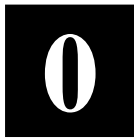

PRECAUTIONS

1. Read these instructions

All the safety and operating instructions should be read before the product is operated.

2. Heed all warnings

All warnings on the product and in the instruction manual should be adhered to.



The symbol indicates the following items, please carefully read the description next to each symbol.

- a. Failure to follow the safety instruction given may directly endanger people, cause damage to the system or to other equipment.
- b. The requirements to make this device work, including hardware, computer settings, network settings, and operation procedures.
- c. The tips to make using this device easier, more convenient and more efficient.

3. Servicing

Do not attempt to service this video product yourself as opening or removing covers may expose you to dangerous voltage or other hazards. Refer all servicing to qualified service personnel.

Trademarks

All names used in this manual for hardware and software are probably registered trademarks of respective companies.

Liability

Every care has been taken during writing this manual. Please inform your local office if you find any inaccuracies or omissions. We cannot be held responsible for any typographical or technical errors and reserve the right to make changes to the product and manuals without prior notice.

FCC/CE Regulation

NOTE: This equipment has been tested and found to comply with the limits for a Class A digital device, pursuant to Part 15 of the FCC Rules. These limits are designed to provide reasonable protection against harmful interference when the equipment is operated in a commercial environment. This equipment generates, uses,

and can radiate radio frequency energy and, if not installed and used in accordance with the instruction manual, may cause harmful interference to radio communications. Operation of this equipment in a residential area is likely to cause harmful interference in which case the user will be required to correct the interference at his own expense.

Table of Contents

0	<i>PRECAUTIONS</i>	<i>0-1</i>
	Trademarks	0-1
	Liability	0-1
	FCC/CE Regulation	0-1
1	<i>INTRODUCTION</i>	<i>1-1</i>
1.1	Package Contents	1-1
1.2	Features and Benefits	1-2
1.3	Safety Instructions	1-4
1.4	Physical Description	1-6
1.5	Basic Connections	1-8
1.6	Installation Procedure	1-9
1.6.1	Ceiling Mount	1-9
1.6.2	Wall Mount	1-11
1.6.3	Camera Adjustment	1-13
1.7	Product Specification	1-15

1

INTRODUCTION

1.1 Package Contents

ACM-3210 series
(DC12V / PoE)



Power Adaptor (Option)



Product CD



Accessory



Warranty Card



Drill Template

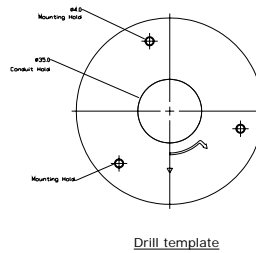

1.2 Features and Benefits

This IP device is a cutting-edge digital video transmission device. It can compress and transmit real time images with outstanding images quality (D1, 720x480) at reasonable bandwidth through a standard TCP/IP network. That is because it is Ethernet ready and has the powerful ARM9 SoC and the MPEG-4 compression ASIC inside. In addition, with these powerful hardware platform, excellent SDK support and powerful respective apparatuses (e.g. the transcoder), this IP device is your best choice building up either conventional IP surveillance system or intelligent IP surveillance system.

- **Real-time MPEG-4 Compression**

With hardware MPEG-4 compression chip inside, the composite video inputs can be efficiently compressed into MPEG-4 bit stream without any delay. The ASIC base compression engine can support not only CIF, but also FULL D1 image resolution.

- **Digital Time Code Embedded**

The “Digital Time Code Embedded” function is to embed the recording time in the MPEG bit stream. Therefore, each image frame has its respective time when it was recorded. It is very useful when users want to find the video at an exact time or between a certain time intervals.

- **DDNS Supported**

This IP device supports DDNS (Dynamic Domain Name Server), users can set this IP device at a virtual domain name (such as cam1.Taipei.xxx) at dynamic IP. Everyone can use the virtual domain name to view the video anywhere that has the access to the internet.

- **Build-in Hardware Motion Detection**

No more external motion sensors are required. Each IP device can be set up to 3 detection areas. By tuning the object size and sensitivity, it is very reliable to fit into your environment. Besides, hardware motion detection delivers better sensitivity and responds faster than software motion detection.

- **Bundle Powerful Surveillance Software**

To extend the capabilities of this IP device, a powerful surveillance program is included in the package and is very free to use. Users can easily

utilize the existing PC to be a digital video recorder. Schedule recording and manual recording keep every important image recorded in the local hard disk. Reliable and accurate motion detection with instant warning makes you responsive in every condition. Quick and simple search and playback function lets you easily find the images you want.

- **Software Development Kit Support**

This IP device can be integrated or controlled by user's application program through the Streaming Library or ActiveX control. With its high level programming interface, software developer's time and efforts to is highly reduced.

1.3 Safety Instructions

- **Don't use the power supply with other voltages**

This device is likely to be damaged or damage other equipments / personnel, if you use a power supply with different voltage than the one included with this device. All warranty of this product will be voided in the situations above.

- **Don't open the housing of the product**

- **Cleaning**

Disconnect this video product from the power supply before cleaning.

- **Attachments**

Do not use attachments not recommended by the video product manufacturer as they may cause hazards.

- **Water and Moisture**

Do not use this video product near water, for example, near a bathtub, washbowl, kitchen sink, or laundry tub, in a wet basement, or near a swimming pool and the like.

- **Don't use accessories not recommended by the manufacturer**

- **Only install this device and the power supply in a dry place protected from weather**

- **Servicing**

Do not attempt to service this video product yourself as opening or removing covers may expose you to dangerous voltage or other hazards. Refer all servicing to qualified service personnel.

- **Damage Requiring service**

Disconnect this video product from the power supply immediately and refer servicing to qualified service personnel under the following conditions.

1. When the power-supply cord or plug is damaged.
2. If liquid has been spilled, or objects have fallen into the video product.
3. If the video product has been exposed to rain or water directly.

4. If the video product does not operate normally by following the operating Instructions in this manual. Adjust only those controls that are covered by the instruction manual as an improper adjustment . Other controls may result in damage and will often require extensive work by a qualified technician to restore the video product to its normal operation.

- **Safety Check**

Upon completion of any service or repairs to this video product, ask the service technician to perform safety checks to determine that the video product is in proper operating condition.

1.4 Physical Description



1. Ethernet Port

The IP device connects to the Ethernet via a standard RJ45 connector. Supporting NWAY, this IP device can auto detect the speed of local network segment (10Base-T/100Base-TX Ethernet).

2. Power Input

If your power input is DC12V. Please follow the description on the connector to connect to power.



PIN	NAME	DESCRIPTION
1	12V	DC Power Input
2	GND	Ground Pin

3. Reset Button

Step 1: Switch off IP device by disconnecting the power cable

Step 2: Press and continue to hold the Reset Button. Reconnect the power cable while continuing to hold the reset button.

Step 3: Keep holding the reset button depressed for a while, release the reset button. The unit will start up with factory default settings.

4. **Audio Input / Output**

The IP device supports audio input and output with terminal block.

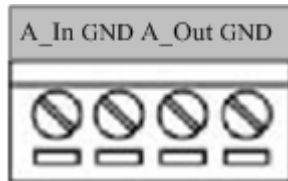

1.5 Basic Connections

Follow the procedures below to connect the IP device to the respective apparatuses.

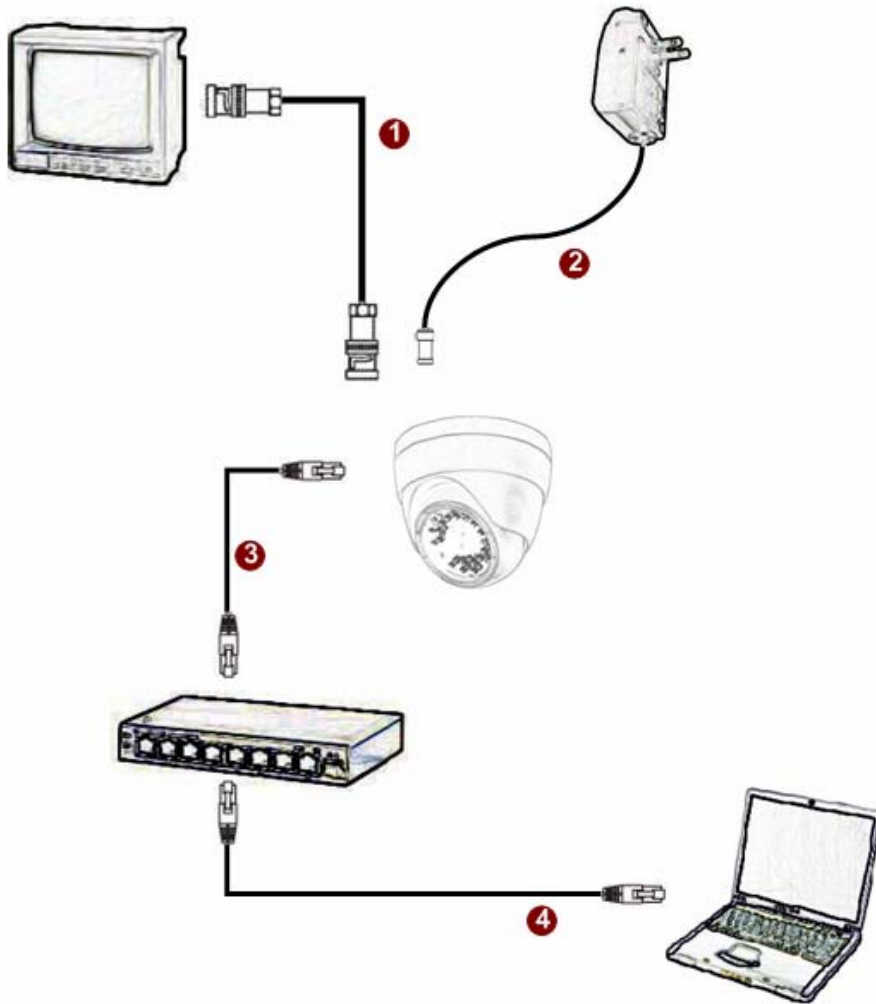

1. Connect an analog monitor to IP device video out (BNC connector).
2. Connect the power adaptor to IP device
3. Connect IP device's ethernet port to an Ethernet (RJ45 connectors). If your IP device has PoE built-in, you can regard it as a PD and connect it directly to a PSE device like PoE switch.
4. Connect a PC to the Ethernet hub (RJ45 connectors)



NOTE: You may find a support package to help you getting familiar with PoE. Please visit our web site, and get the support document TS-00040.

1.6 Installation Procedure

1.6.1 Ceiling Mount

1.6.1.1 Use the drill template, and drill a hole with $\phi 35$ on the ceiling

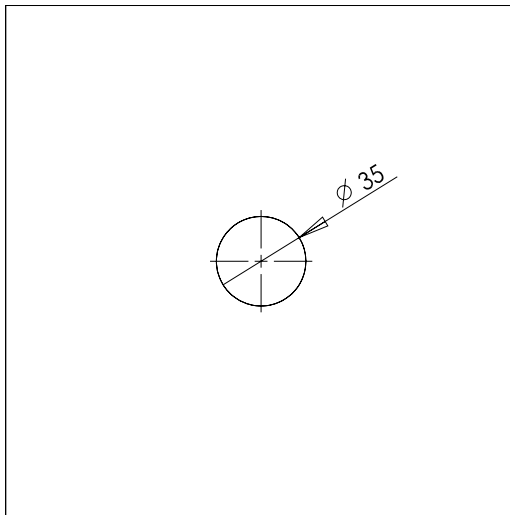

1.6.1.2 Tighten the plate to ceiling with M4*20 screws

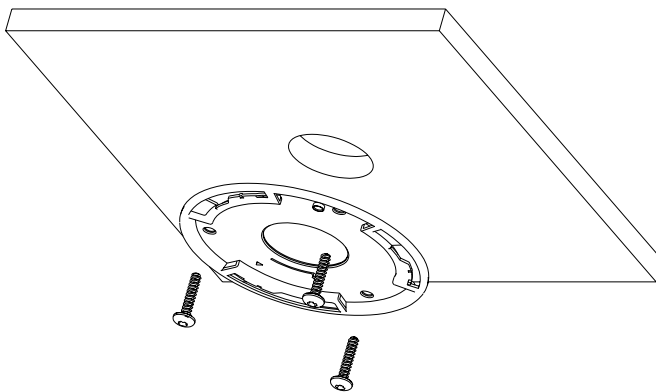

1.6.1.3 Connect cables through the hole on the ceiling and plate, or on the side of casing

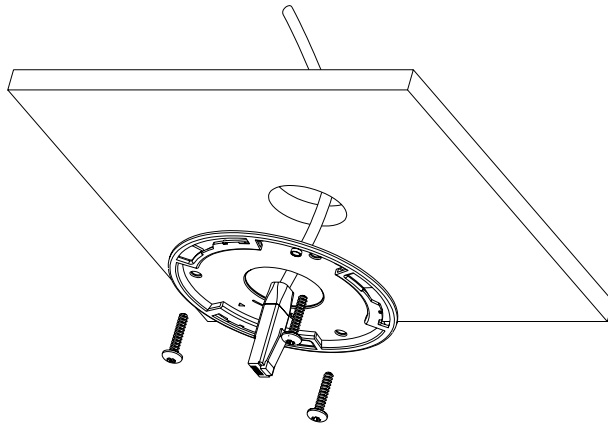

1.6.1.4 Fasten the camera to ceiling

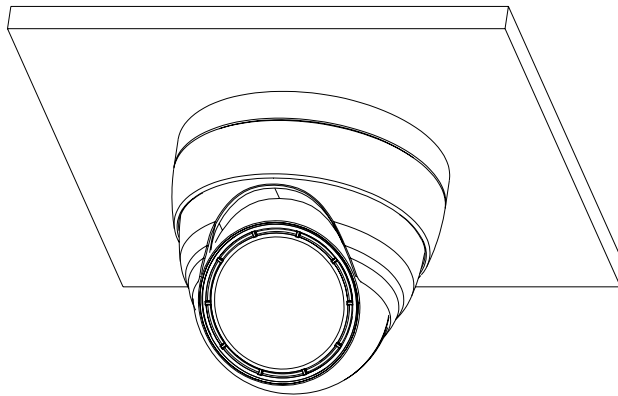

1.6.2 Wall Mount

1.6.2.1 Tighten wall mount bracket to the wall by 3 PAN Head Tapping screws

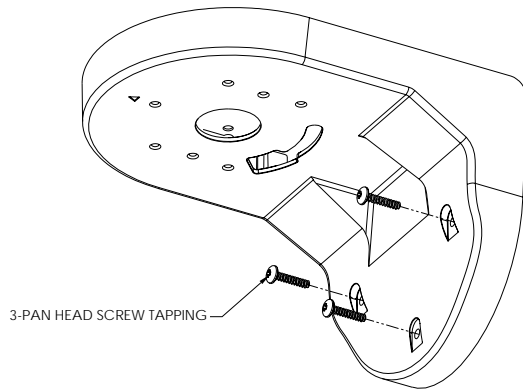

1.6.2.2 Tighten the plate to wall mount bracket with M4*10 screws, and connect all necessary cables through the hole on the plate and wall mount kit

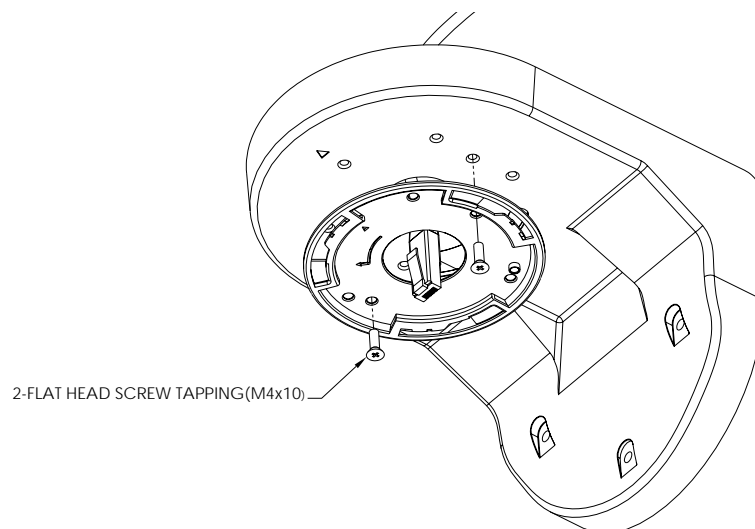

1.6.2.3 Note: that there's a triangle mark on both plate and wall mount kit. Those triangle marks need to fix on the same direction.

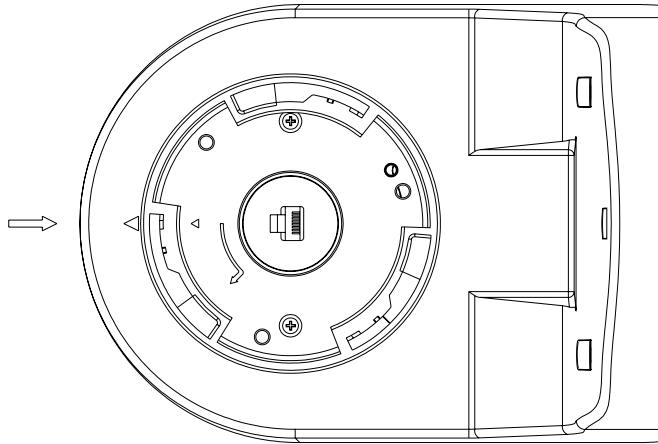

1.6.2.4 Fasten the camera to wall mount kit by turning clockwise direction

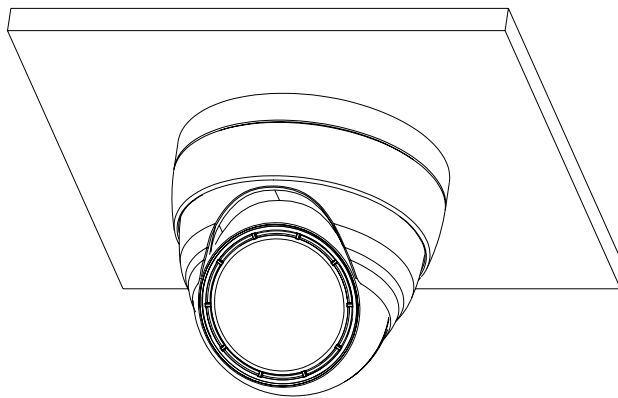

1.6.3 Camera Adjustment

3-axis design enables easily adjustment in every angle

1.6.3.1 X-axis – Panning View with angle range $0^{\circ}\sim 360^{\circ}$

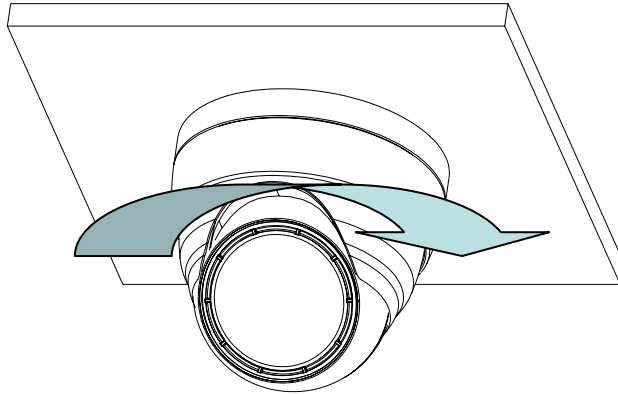

1.6.3.2 Y-axis – Tilting View with angle range $0^{\circ}\sim 180^{\circ}$

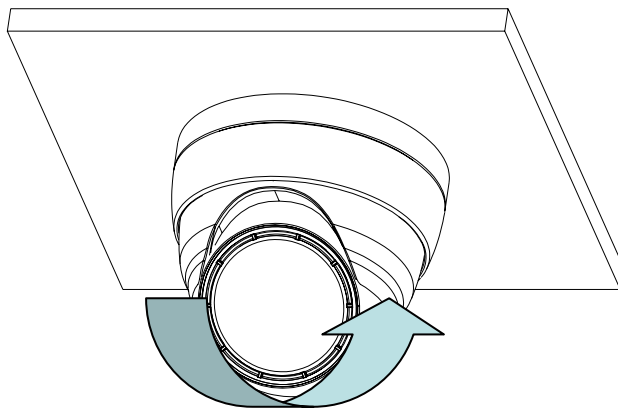

1.6.3.3 Z-axis – Rotating View with angle range $0^{\circ} \sim 360^{\circ}$

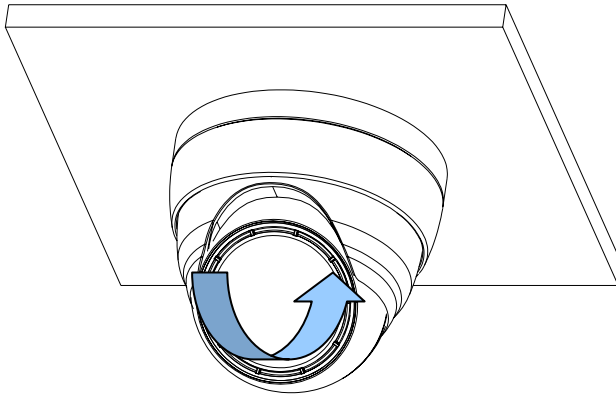

1.7 Product Specification

		ACM-3211
Image	Device	SONY SuperHAD CCD
	Size	1/3" inch
	Effective Pixels	537 x 505 (NTSC); 537 x 597 (PAL)
	Horizontal Resolution	420 TVL
Min. scene Illumination	Color	0 Lux at F2.0 (w/IR) IR LED ON at 4 Lux / Controlled by a CDS sensor
	IR LED	IR LED x 24 (850nm)
	CDS Sensor	Yes
	IR Sensitivity	from 700 nm to 1100 nm
	IR Working Distance	10 ~ 15 M (30 IRE)
Lens	Focal Length	f 4.3 mm / F2.0
	Viewing Angle	63° (Horizontal)
Camera Angle Adjustment	X (Panning)	0° ~ 360°
	Y (Tilting)	0° ~ 180°
	Z (Rotating)	0° ~ 360°
Synchronization	Sync. System	Internal
Day/Night Functions	Mechanical IR Cut Filter	N/A
	Motion Detection	Yes (3 Windows)
Functions	Electronic Shutter	1/60 ~ 1/100,000 sec. (NTSC) 1/50 ~ 1/100,000 sec. (PAL)
	BLC	Automatic
	AGC	Automatic
	White Balance	AWB
	S/N Ratio	S/N Ratio
Video Compression	Compression	MPEG-4 SP, MJPEG selectable
	Picture Resolution	Full D1 (720x480 in NTSC, 720x576 in PAL) VGA (640x480 in NTSC, 640x480 in PAL) CIF (352x240 in NTSC, 352x288 in PAL) QCIF (160x112 in NTSC, 176x144 in PAL)
	Bit Rate	28 K ~ 3 M bps
	Image Frame Rate	30 fps at Full D1 resolution (NTSC) 25 fps at Full D1 resolution (PAL)
Audio Input	Compression	8 kHz, Mono, PCM
	Audio Line Input	Unbalanced, 1.4Vp-p, 1Vrms, terminal block
Audio Output	Compression	8 kHz, Mono, PCM
	Audio Line Output	Unbalanced, 1.4Vp-p, 1Vrms, terminal block
External I/O	Reset Button	Factory default
	LED	System status
Network	Ethernet	Ethernet(10/100Base-T), RJ-45 connector
	Protocol	TCP, UDP, IP, HTTP, DHCP, PPPoE, RTP, RTSP, FTP, SMTP, DNS, DDNS, NTP, ICMP, IGMP, ARP, 3GPP
Software	Web Browser	Microsoft Internet Explorer 6.0 or above
	SDK	ActiveX control, C SDK
	Security	Password protection: configured by the administrator
Operating	Temperature	-10 °C ~ 50 °C (14 °F ~ 122 °F)
Power	Power Requirement	PoE (IEEE802.3af) with Class 3
	Power Consumption	5.7 W (DC 12 V) w/ IR ON 7.0 W (PoE) w/ IR ON
Physical	Dimensions (WxHxD)	106.5 mm x 99.8 mm (4.19" x 3.93")
	Weight	320 g (0.7 lb)